



## SAFETY NOTES ON THE UNIT

### WARNING

- To prevent fire or shock hazard, do not expose the unit to rain or moisture.
- Do not use headphones/earphones while driving, cycling, or operating a motorized vehicle. It may create a traffic hazard and is illegal in some areas. It can also be potentially dangerous to play your headphones/earphones at high volume while walking, especially at pedestrian crossings. You should exercise extreme caution or discontinue use in potentially hazardous situations.
- To prevent shock hazards, never open the unit while it is connected to the power source.

### CAUTION

- Do not use headphones/earphones at high volume. Hearing experts advise against continuous, loud and extended play. If you experience a ringing in your ears, reduce volume or discontinue use.
- Keep the volume at a moderate level. This will allow you to hear outside sounds and to be considerate to the people around you.





## SAFETY NOTES ON POWER SOURCES

To avoid battery leakage, fire, damage, explosion, etc., follow the descriptions below.

### DANGER

- Do not carry dry batteries with coins or other metallic objects. It can generate heat if the positive and negative terminals of the batteries are accidentally contacted by a metallic object.

### WARNING

- Use only the Sony AC-E30HG AC power adaptor (not supplied).
- To disconnect the AC power adaptor, only use the plug and not the cable.
- Do not charge a dry battery.
- Check the  and  on the batteries, and be sure to insert them by matching the  and  on the battery to the diagram inside the battery compartment.

### CAUTION

- When you are not going to use your Walkman for a long time, remove the batteries to prevent damage from battery leakage and corrosion.

## About This Manual

The instructions in this manual are for WM-GX322 and WM-GX320. Before you start reading, check your model number. WM-GX322 is the model used for illustration purposes. Any differences in operation are clearly indicated in the text, for example, "GX322 only".

## Precautions

- Do not leave the unit in a location near heat sources, or in a place subject to direct sunlight, excessive dust or sand, moisture, rain, mechanical shock, or in a car with its windows closed.
- Do not wind the headphones/earphones cord around the unit. The buttons may be kept pressed, causing unnecessary battery usage.
- Do not use cassettes longer than 90 minutes except for long continuous playback or recording.
- To prevent accidental recording, break off the cassette tab from side A or B. If you want to reuse the cassette for recording, cover the broken tab with adhesive tape.

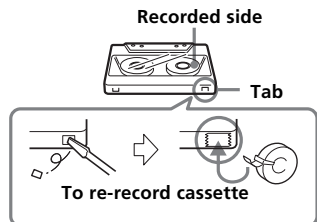

- If the unit has not been used for a long time, set it in the playback mode to warm it up for a few minutes before inserting a cassette.
- For cleaning the case, use a soft cloth slightly moistened with mild detergent solution. Do not use alcohol, benzine or thinner.

If you have any questions or problem concerning your Walkman, please consult your nearest Sony dealer.

## Specifications

- **Frequency range**  
FM: 87.6-108 MHz (North, Central and South America)  
87.5-108 MHz (Italy and Saudi Arabia)  
65.0-107.9 MHz (Eastern Europe)  
87.6-107.9 MHz (Other countries)  
AM: 530-1,710 kHz (North, Central and South America)  
526.5-1,606.5 kHz (Italy and Saudi Arabia)  
531-1,602 kHz (Other countries)
- **Power requirements**  
3V DC batteries R6 (AA) x 2/External DC 3V power sources
- **Power output**  
Speaker: 110 mW + 110 mW (GX322 only)  
Headphones: 5 mW + 5 mW (at 10% harmonic distortion)
- **Dimensions**  
WM-GX322: 116 x 89 x 39 mm (4 5/8 x 3 5/8 x 1 5/8 inches) (w/h/d) incl. projecting parts and controls  
WM-GX320: 116 x 89 x 39.5 mm (4 5/8 x 3 5/8 x 1 5/8 inches) (w/h/d) incl. projecting parts and controls
- **Mass**  
WM-GX322: Approx. 190 g (6.8 oz)  
Approx. 265 g (9.4 oz) incl. batteries and a cassette  
WM-GX320: Approx. 175 g (6.2 oz)  
Approx. 250 g (8.9 oz) incl. batteries and a cassette
- **Supplied accessories**  
Stereo headphones or earphones (1)/Carrying case (1)/Stereo microphone (1)/Microphone stand (1)

Design and specifications are subject to change without notice.

## Troubleshooting

### The sound is unstable or no audio.

- Insert two R6 (size AA) batteries properly.
- Replace all batteries if they are weak.

### Poor tape playback quality.

- Clean the headphones/earphones plug.
- Dirty heads. Clean the heads and tape path with a cotton swab slightly moistened with cleaning fluid or alcohol.

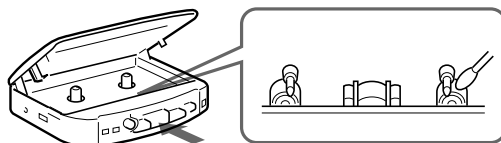

### The volume is not turned up.

- AVLS is set to LIMIT.

## Preparations

### To insert batteries

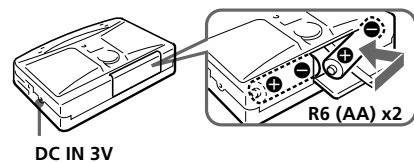

### Battery life (approximate hours) (EIAJ)\*

	Sony alkaline LR6 ( SG )	Sony R6P ( SR )
playback	22	7
radio	48	16
mic recording	11	3.5
radio recording	10	3

### Using headphones/earphones

\* Measured value by the standard of EIAJ (Electronic Industries Association of Japan). (Using a Sony HF series cassette tape)

### Notes

- The BATTERY indicator dims when the batteries become weak or exhausted. Replace them with new ones.
- The battery life may shorten depending on the operation of the unit.
- For maximum performance we recommend that you use alkaline batteries.
- If the battery compartment lid comes off, attach it as shown.

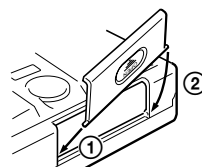

### To use external power

- For house current: Connect AC-E30HG AC power adaptor (not supplied) to the DC IN 3V jack.
- Specifications for AC-E30HG varies for each area. Check your local voltage and the shape of plug before purchasing.



The polarity of the plug

## Location of parts and controls

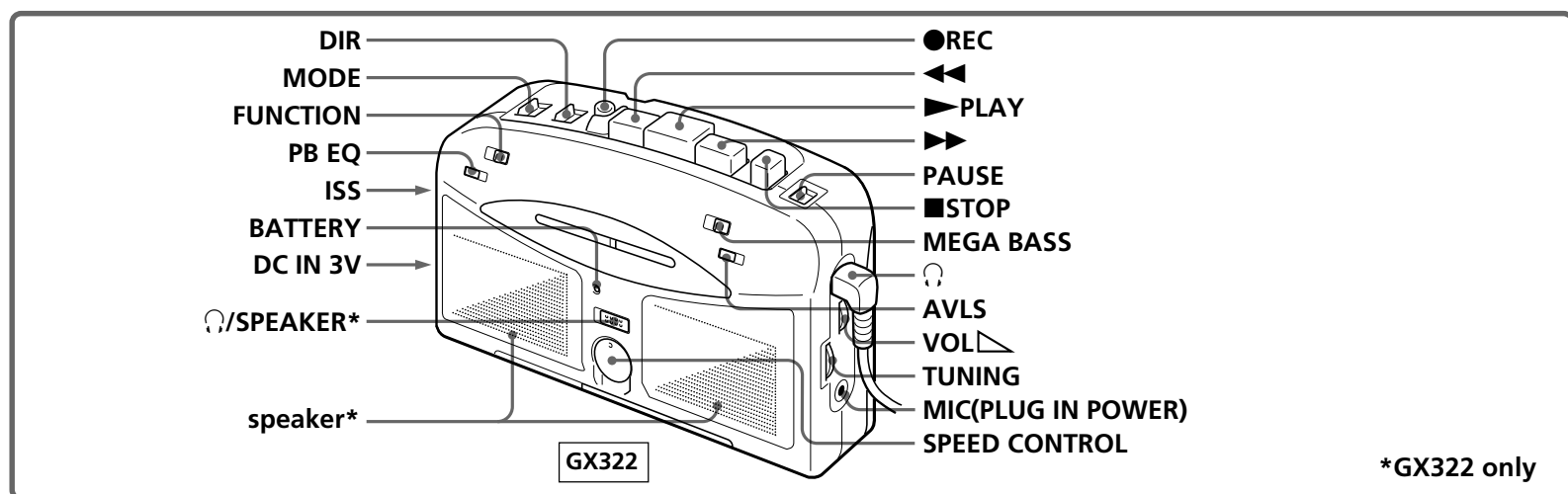

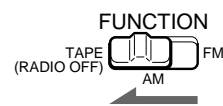

## Playing a tape

- 1 Set the FUNCTION to TAPE(RADIO OFF).



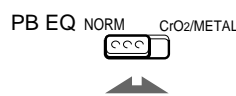



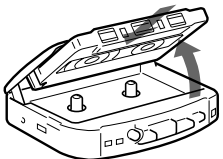

- 2 Set PB EQ (playback equalizer) to match the tape type.





- 3 Insert a cassette and press  PLAY.



To	Press or set
Stop playback*	 STOP
Fast-forward or rewind the tape**	 or 
Change sides	DIR
Play both sides once	MODE to 
Play both sides repeatedly	MODE to 

\* When the tape ends, the depressed button  PLAY is released automatically (Auto shut-off function).

### \*\*Notes on fast-forward and rewind

- Check tape direction and choose  or  accordingly.
- If you leave the unit after the tape has been wound or rewound, the batteries will be consumed rapidly. Be sure to press .





### To use the speakers (GX322 only)

Set /SPEAKER to SPEAKER. The sound will play from the speakers and no sound from the headphones/earphones. When the speakers are in use, the AVLS and MEGA BASS function will not operate.

### To limit the maximum volume automatically

Set AVLS (Automatic Volume Limiter System) to LIMIT. The maximum volume is kept down to protect your ears, even if you turn the volume up. To cancel the AVLS function, set AVLS to NORM.

### Tips

- To switch the playback side, set DIR to  or .
- To select the direction of the tape, set MODE to  to play both sides of the tape once, or  to play both sides repeatedly.
- To emphasize deep bass sound, set MEGA BASS to MAX or MID.

### Notes

- When you set AVLS to LIMIT;
  - the MEGA BASS effect is reduced.
  - turn down the volume, if the bass-boosted sound becomes distorted or unstable.
- Do not open the cassette holder while the tape is running.

### Adjusting the Playback speed

You can choose from approximately +25% to -20% playback speed.

Turn SPEED CONTROL to the left (slows down) or to the right (speeds up). To put back to the normal speed turn SPEED CONTROL to the middle.

Playback Speed	Turn the knob
Slow speed	to the - direction
Fast speed	to the + direction
Normal speed	to the middle



### Note

- You cannot change the recording speed by the SPEED CONTROL.

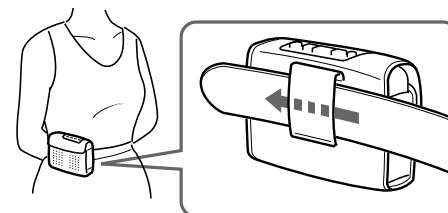
### To use the carrying case



## Recording

- 1 Insert a TYPE I (normal) tape with the side you want to record facing forward.
- 2 Set DIR to . When DIR is set to , you cannot press .



- 3 To record from the radio  
Set FUNCTION to AM or FM.

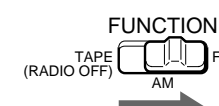

### To record from the microphone

Set FUNCTION to TAPE (RADIO OFF).

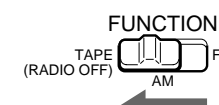

- 4 To record from the radio  
Tune to the station you want.

### To record from the microphone

Connect the supplied microphone to MIC(PLUG IN POWER) jack.

- 5 Press  REC.  
The recording level is automatically adjusted.



### To pause a recording

Set PAUSE to the direction of the arrow during recording, the recording will pause. To record, set PAUSE to the opposite direction of the arrow.

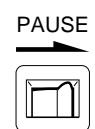

### To stop recording

Press .

### To record on the reverse side

Turn over the tape after recording stops on the forward side. The recording function works only on the forward side.

### When using the supplied microphone stand

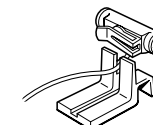

### Tips

- To reduce noise while recording AM programs, set ISS to the position that most decreases the noise.
- Adjusting the volume or setting MEGA BASS and AVLS will not affect the recording level. These controls will change the sound level you hear.

### Notes

- Do not use a CrO<sub>2</sub> (TYPE II) or metal (TYPE IV) tape for recording.
- When recording with the microphone, do not place it near a lamp cord or a fluorescent lamp to avoid interference noise.
- If a howling occurs, turn down the volume.
- When recording with the microphone, the sound to be recorded cannot be heard through the speakers. (GX322)